



 **Dagger**

OWNER'S MANUAL

WELCOME TO THE FAMILY

As a Dagger kayak owner, you're in good company with some of the world's most passionate and well-known paddlers. Dagger's reputation is for being at the cutting-edge of performance, comfort, and value. Your Dagger kayak will provide years of adventure wherever you want to go; and to places you haven't yet thought of going.

Back in 1988, four buddies created the first of what would become the industry standard in paddlesports. Today, every Dagger kayak is built with over two decades of the latest material and design innovations. They've been team tested and paddler proven to handle water anywhere it moves.

A lot has changed over the years but true to the very beginning, one thing remains the same. Our kayaks still run on excitement.

Thanks for choosing Dagger.

BE A PART OF THE COMMUNITY!

As a Dagger owner, you've joined the ranks of one of the largest and most active groups of paddlers on the planet. Get the most out of your experience by connecting with them using our online communities.

Visit Dagger.com or TeamDagger.com to connect with fans, owners, and Dagger Pro Staff.

This owner's manual and additional resources are available at www.dagger.com.

CONTENTS

- 2 KAYAK ANATOMY: WHITEWATER
- 3 KAYAK ANATOMY: RECREATIONAL/TOURING
- 4 SAFETY
- 5 RECREATIONAL & TOURING OUTFITTING
- 6 SKEGS/FOOT BRACES
- 7 STOWING YOUR GEAR
- 8 STORAGE/TRANSPORT
- 9 CARE/MAINTENANCE
- 10 ACCESSORIES
- 12 LIMITED WARRANTY
- 13 SERVICE & SUPPORT

KAYAK ANATOMY: WHITEWATER

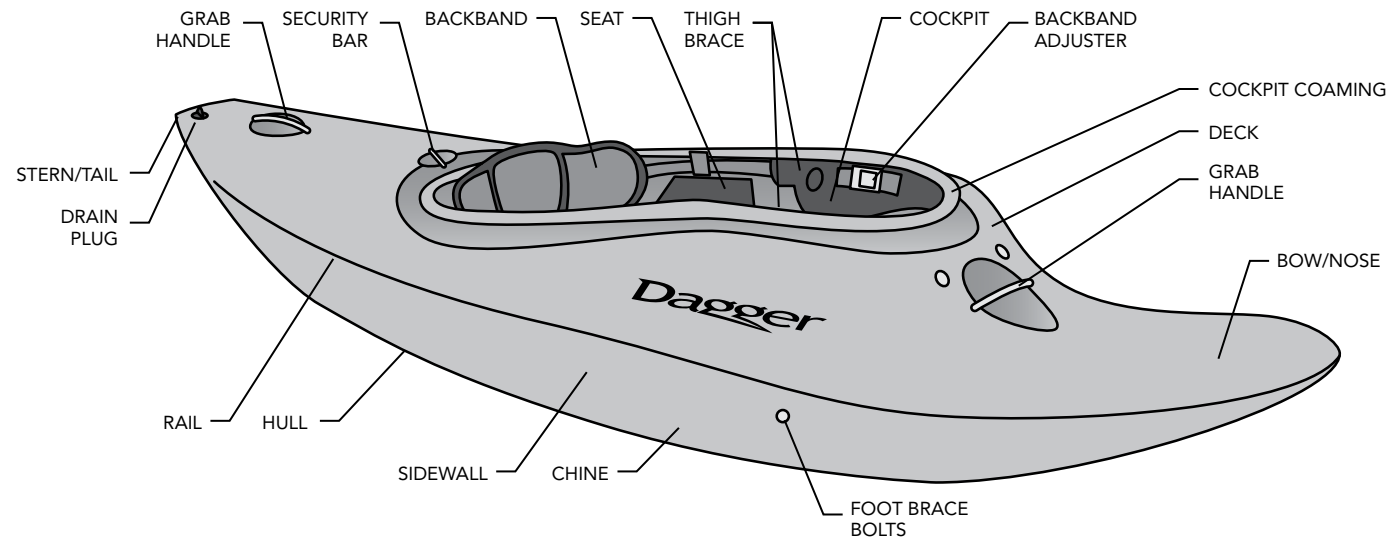

FEATURES IN DETAIL

BOW / NOSE: The front of the kayak.

STERN / TAIL: The back of the kayak.

DECK: The top of the kayak above the waterline.

HULL: The bottom of the kayak below the waterline.

SIDEWALL: The side of the kayak.

CHINE: The edge where the hull meets the sidewall - Below the waterline.

RAIL: The edge where the sidewall meets the deck - Above the waterline.

COCKPIT: The area where you sit - surrounded by the cockpit coaming.

FOOT BRACE / ADJUSTABLE BULKHEAD: Adjustable foam pads or bulkhead plates used to brace your feet against.

THIGH BRACES: Shaped, padded braces under which your thighs and knees are placed to help control the roll of the kayak.

SEAT & SEATBACK: The seat includes an adjustable backband to provide lumbar support.

SECURITY BAR: A bar fixed to the kayak which can be used to lock your kayak to prevent theft.

GRAB HANDLE: Handles at both ends used to carry the kayak and rescue.

DRAIN PLUG: Plastic plug that screws into a threaded insert at the stern - Used to easily empty water that has accumulated in the kayak.

KAYAK ANATOMY: RECREATIONAL/TOURING

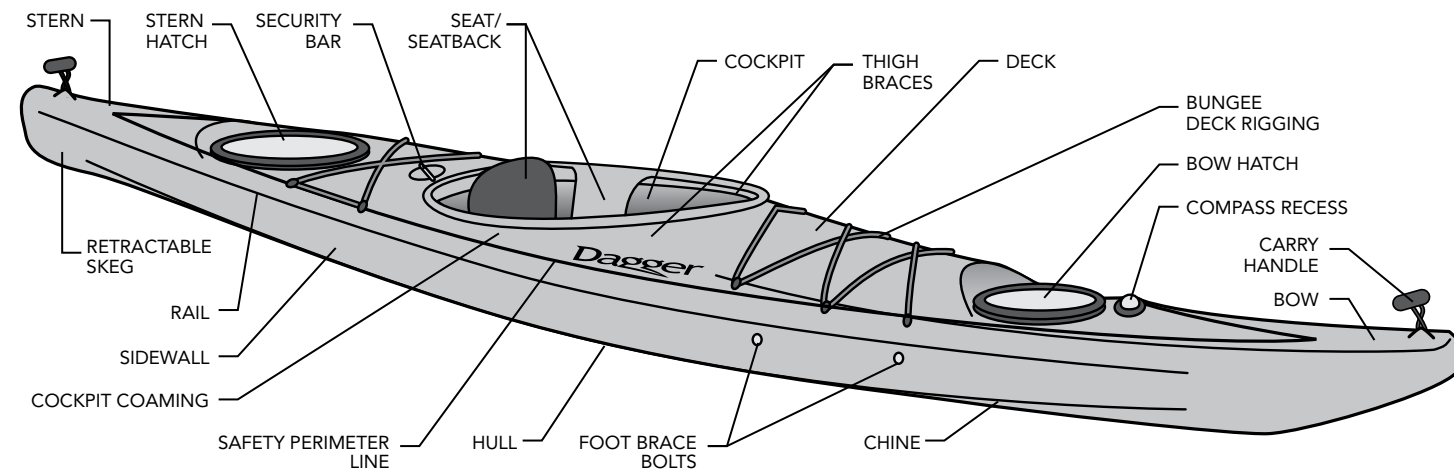

FEATURES IN DETAIL

BOW: The front of the kayak.

STERN: The back of the kayak.

DECK: The top of the kayak.

HULL: The bottom of the kayak.

SIDEWALL: The side of the kayak.

CHINE: The edge where the hull meets the sidewall.

RAIL: The edge where the sidewall meets the deck - Above the waterline.

COCKPIT: The area where you sit.

FOOT BRACE: Adjustable pedals to brace your foot against.

THIGH BRACES: Shaped, padded braces under which your thighs and knees are placed to help control the roll of the kayak.

SEAT & SEATBACK: The seat includes an integral seatback or adjustable backband to provide lumbar support.

SECURITY BAR: A bar fixed to the kayak which can be used to lock your kayak to prevent theft.

RETRACTABLE SKEG: A blade at the stern of the kayak which can be lowered to help the boat to track.

CARRY HANDLE: Padded plastic handles at both ends of the boat used to carry and secure the boat.

COMPASS RECESS: Some touring kayaks feature a position for a deck-mounted compass.

HATCHES: Rubber covers allow access to the sealed compartments below deck. Provides dry storage as well as secure buoyancy.

BUNGEE DECK RIGGING: Useful pattern of elasticised rope on the deck of the kayak, used to store additional items.

SAFETY PERIMETER LINES: Used for rescue; reflective for better visibility.

* Your model features may differ from diagram.

SAFETY

Any person using kayaks built and/or sold by Dagger is personally responsible for determining that their abilities are equal or superior to the conditions encountered and exercising proper judgment in choice of where and when to paddle.

Any person using Dagger kayaks assumes all risks and takes complete responsibility for any and all damages, or injuries, including death, which may result from use of or participation in Dagger kayaks.

Consult your physician prior to beginning your paddlesport training.

DO:

- Wear a Coast Guard approved personal flotation device (PFD).
- Wear a helmet when paddling whitewater or in the ocean.
- Get paddlesports instruction from a licensed or certified instructor.
- Dress appropriately for weather conditions; cold water and/or weather can result in hypothermia.
- Check your equipment prior to each use for signs of wear or failure.
- Scout unfamiliar waters. If necessary, paddle to shore and carry your boat past uncertain areas.
- Stay aware of appropriate river water levels, tidal changes, dangerous currents, and weather changes.
- Follow manufacturer's recommendations for use and outfitting of your kayak.
- Leave your paddling location and agenda with someone at home before departing.
- Obtain certified first aid and rescue training and carry first aid and rescue equipment.
- Always use supplemental flotation.

DON'T:

- Never exceed your ability and assess how far and how long you can paddle or swim.
- Never paddle alone.
- Never consume alcohol, drugs, or any other substance that may affect your coordination, judgment, or ability when paddling.
- Never paddle in flood conditions.
- Never allow minors to use the boat without adult supervision.
- Avoid bracing yourself in the kayak in such a way that you have to release any outfitting to escape.
- Do not impair entry or exit access to the kayak when installing additional outfitting.

WARNING:

Kayaking can be hazardous with potential risk of serious injury and even death.

SEAT ADJUSTMENT

Dagger Recreational and Touring seating systems are designed for use by the majority of people without any adjustment required.

For full information on Dagger Whitewater outfitting, please reference the Contour Ergo adjustment manual included with your Dagger Whitewater kayak.

For more step-by-step instructions, visit Dagger.com

THIGH BRACE ADJUSTMENT

Some Dagger kayaks are outfitted with adjustable thigh braces. Thigh braces hold your knees against the inside of the kayak increasing your control over the boat's pitch and roll.

- 1 Loosen the bolts holding the thigh braces to the kayak using a philips head screwdriver. You need to completely remove the front bolt only.
- 2 Move each thigh brace forwards or backwards until comfortable and re-tighten the retaining bolts.

IMPORTANT:

One of the most important considerations in using your kayak is the way it feels to you – how comfortably it fits and how easy it is to get in and out of.

RECREATIONAL & TOURING OUTFITTING

BACKREST ADJUSTMENT

Most Dagger kayaks have adjustable back rests to ensure the best fit and provide lumbar support. The backrest should be adjusted enough that you feel secure while remaining comfortable. Do not overtighten as this could impair your exit or cause back injury.

HEIGHT ADJUSTABLE BACKREST

The height of the seatback can be raised or lowered using the toggle located at the front of the seat base. To raise the backrest, pull the nylon strap forward and it will lock into place. To lower the backrest, push down on the plastic tab to release the nylon strap (Contour Surround Excluded).

BACKBAND

Use the sliders on the back of the backband to adjust the tension further up or backwards.

LEGLIFTER

- 1 While seated in the kayak, locate the straps on each side of the front of the seat. Pull the straps upwards until the leglifter is raised to your desired comfort level. Do not over tighten the leglifter system. Do not restrict exit from the kayak.
- 2 To lower the leglifter, lift and push on the web locking buckle tabs located on each leglifter strap.



Backrest



Backband



Contour Surround

SKEGS / FOOT BRACES

RETRACTABLE SKEG

Some Dagger kayaks have a retractable skeg to help aid in boat control in certain wind and sea conditions. The deployment of the skeg helps balance the boat to the specific conditions by adding more tracking at the stern of the boat. Experiment with different skeg positions to find the best balance point.

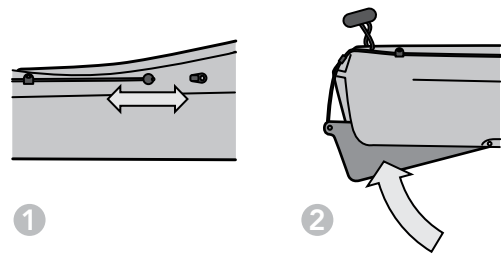

Skeg system design may vary from image above

RETRACTABLE SKEG OPERATION

- 1 Cable skeg- Find the skeg slider box on the right side of the cockpit. Push the slider back to deploy and forward to uphaul the skeg blade. Be careful not to force the slider as small rocks or debris may jam the skeg blade causing the cable to kink. If this is the case clean out the skeg box with a thin blade or screwdriver.
- 2 Rope skeg- Find the lanyard on the right side of the deck just behind the cockpit. Lift and release the tab out of the cleat to drop the skeg down. The spring-loaded system will deply the skeg. Pull the tab forward to raise the skeg and re-cleat after adjustment is made.

SLIDELOCK FOOT BRACES

First, sit in an upright position to begin adjusting the footpegs. There is a gray plastic rod extending from the footpeg to your knee that adjusts the position. Lift the rod slightly to release the peg and then either slide the peg forward or back to find the correct position.

Releasing the rod will lock it in place. With just a slight amount of foot pressure the peg should be snug against your foot.



SLIDELOCK XL SYSTEM



KEEPER XL SYSTEM

KEEPERS FOOTBRACES:

The adjustment lever is located on the backside of the footpedal. To adjust, squeeze the lever and slide the footpeg to the desired location. Release the lever to lock it in place.

STOWING

There is stowage space behind the seat and in front of the footbraces in many Dagger kayaks. To stow gear in other areas of a Dagger touring/recreational kayak, simply open one of the hatches and slide it in.

Heavier items should be placed towards the bottom and center of the kayak and lighter equipment on top and to the ends.

If gear is stowed in the main cockpit area, ensure that there are no loose items impeding your exit from the kayak. It is also a good idea to place your items in a waterproof bag and tie it in to prevent loss in the event of a capsiz.

Dagger kayaks with hatches have interior foam walls or bulkheads that create waterproof compartments for gear storage and buoyancy. It is still a good idea to store items in a drybag in the chance leakage may occur.

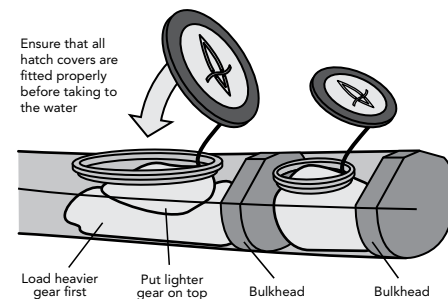

Hatches not available in all models

STOWING YOUR GEAR

DECK RIGGING

Dagger recreation/touring kayaks feature deck rigging for stowing useful items: A spare take-apart paddle, bilge pump, dry bag, first aid kit, etc.

Valuable items should be tied to the rigging to prevent loss. Check the security of stashed gear periodically and remember that heavy items attached to the deck of the kayak can reduce the stability of the craft.

Touring kayaks feature perimeter safety lines which, in addition to rigging, can be used for rescues and are reflective for increased visibility.

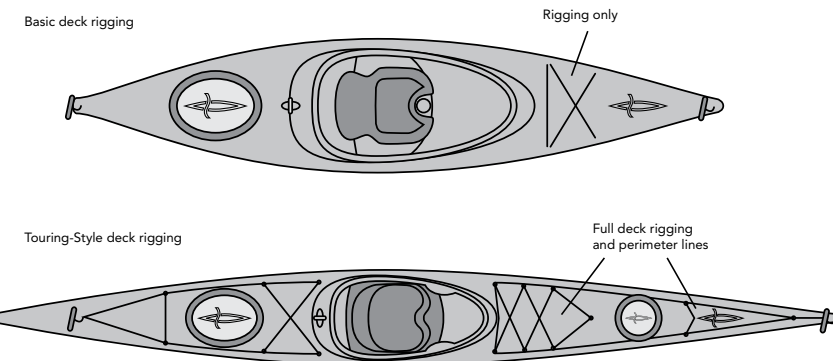

STORAGE / TRANSPORT

STORING YOUR KAYAK

Boats made from polyethylene plastic are strong, rigid and highly impact resistant, but due to the nature of plastic in general, it is important to store your boat properly. It is always best to store your kayak indoors, out of direct sunlight and protected from inclement weather.

Preferably, you should stand your boat on end or hang it suspended by slings. Hanging your boat from its grab loops or handles increases the chance of warpage. You can also store your boat on the floor, upside down. When storing upside down, it is recommended that the load is spread evenly along the length of the boat.

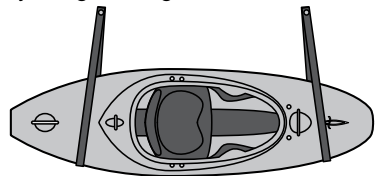

Use slings or webbing straps suspended from the ceiling or wall.
Use foam to pad the areas where the kayak comes into contact with the wall.

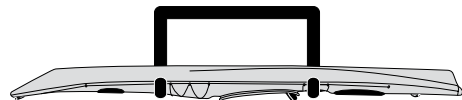

Your boat can also be stored hull up on parallel bars with weight supported evenly throughout.

CAUTION:

Do not suspend your kayak by using the grab loops at either end of the boat. This can cause the hull to distort over time.

TRANSPORTING YOUR KAYAK

Because of their light weight and shape, kayaks are ideally suited for car topping. Your primary concern in carrying your kayak is that it stays securely tied to the vehicle. As with storage, another concern should be potential distortion of the hull.

Car-topping the kayak is best done with a quality roof rack specifically designed for attaching kayaks (Thule, Yakima). Foam blocks/cradles attached to the rack are another option. The boat should be tied to the vehicle as well as the rack by its grab handles.

Over tightening bow and stern lines will increase the likelihood of warpage as will leaving the boat tied tightly in the sun for prolonged periods.

IMPORTANT:

It is recommended to always stop shortly after the start of your trip to make sure all fittings and connections are secure and that the kayak will not shift during travel.

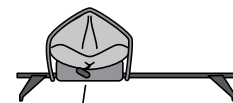
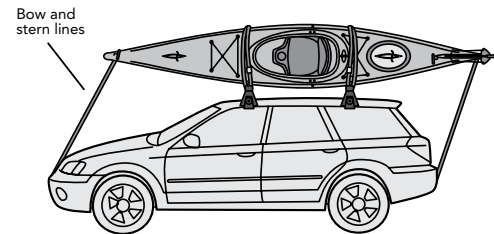

Foam cradle or pad
Carry a single kayak cockpit down

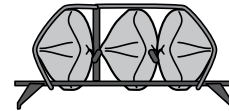

Carry two or more kayaks cockpit to cockpit - use upright roof bars

INCLEMENT WEATHER

If traveling when inclement weather is threatening, position the kayak upside down if possible. A kayak heavy with water can become dangerous. Use a portage cover to seal the cockpit if an upside down position is not possible. Periodically check your straps to ensure they have not stretched while wet.

CARE

Our rotomolded kayaks are made of high-density linear polyethylene, which is virtually maintenance free. A minimal amount of care in storage and transporting will help the kayak maintain a like-new condition for many years.

WHITewater CARE

Whitewater kayaks are built to withstand more aggressive use than recreation or touring models. However, a certain amount of impact and abrasion damage is to be expected due to the nature of whitewater paddling.

Continual exposure to abrasion can roughen the hull surface. Scratching is often cosmetic or superficial and requires no repair.

It is important to be able to determine when damage is cosmetic or extends to impacting the structure of the hull. Impacts are much more likely than scratches to result in structural damage. Inspect your hull after suffering a collision.

As strong and durable as it is, polyethylene is not indestructible. However, should the worst happen, it is repairable – simply contact your local Dagger dealer.

CLEANING

Usually, a quick rinse of fresh water is all that is necessary to keep your kayak clean and functioning in good order. This is very important after paddling in salt water. Be sure to rinse the skeg, cables, and foot braces with fresh water to remove salt residue. To minimize long-term degradation caused by UV exposure, use an ultraviolet protectant such as 303 Protectant, available at your local dealer or HarmonyGear.com.

REPAIR OPTIONS

Although it is unlikely that your Dagger kayak will need any repairs during its lifetime, it is possible that a hull crack or puncture may occur due to extreme impact or contact with a sharp object. If this happens, contact your local Dagger dealer to determine if the damage falls under the boat's warranty (see warranty section).

We will need the serial number of your kayak, a good description of the damage (a photograph is required) and a description of the incident during which the damage occurred. All of this information will help us determine the best course of action.

CARE / MAINTENANCE

HULL DISTORTION

Polyethylene will become more flexible when in warm conditions such as a hot, sunny day. Improper storage or transportation of a plastic boat, especially in the heat, can potentially distort the shape of the hull on your boat.

If your kayak does become the victim of slight distortion, correction is a simple process. Brief exposure to the heat of the sun is often all it takes to restore the hull to its original shape. If that doesn't work, the hull can usually be restored by applying heat to the outside of the boat with a hair dryer. Take care – high, focused heat could cause damage.

When the hull is pliable enough, it can be pushed back into shape by hand. A weight can be placed inside the boat to maintain the shape of the hull as it cools. Allow 24 hours to ensure the process is completed.

WARNING:

Avoid dragging your kayak across the ground to prolong its life and maintain its look and performance. Two people, using the carrying handles, is the best way to transport a longer kayak.

ACCESSORIES

ESSENTIALS CHECKLIST:

PERSONAL FLOTATION DEVICE (PFD)

A USCG approved, comfortable and secure fitting PFD should be worn at all times. Shorter PFDs are available that are ideal for kayak paddling.

SAFETY EQUIPMENT

USCG regulations require an audible signal device (a horn or whistle) to be used in all watercraft. In addition, for recreational and touring kayaks, it is recommended that all paddlers carry a bilge pump (to drain water from the kayak), and a paddle float. Be sure to secure training in the operation of a paddlefloat.

WHITewater ESSENTIALS CHECKLIST:

In addition to the essentials needed for all paddlesports, whitewater kayaking requires an additional level of protective gear.

HELMET

You should always wear an appropriate helmet while paddling whitewater.

SPRAYSKIRT

A sprayskirt is worn by the paddler to create a watertight seal, preventing the cockpit from filling up with water. You should always paddle with a spray skirt in place to facilitate rolling and prevent the kayak from getting swamped.

PERSONAL GEAR

Items you should keep with you on every trip include sunscreen, a hat, sunglasses, plenty of drinking water, insect repellent, compass, waterproof flashlight, matches or lighter, pocket knife, and a first aid kit.

PADDLE

Choosing a paddle is almost as important as your choice of boat. Blade shape, length, weight, and material all offer different experiences. It is also strongly recommended that you have a spare paddle that can be easily stowed on your deck.

WHITewater PADDLE

Typically, a whitewater paddle will be shorter than the average touring paddle and have a larger blade face. Your local Dagger dealer should be able to help you decide on a paddle to suit your needs. It is always a good idea to carry a backup paddle that can be broken down to fit in the stern of your kayak.

THROW BAG

In the event of an emergency while on the water, a throw bag can help you reach a swimmer or help free your kayak. A throwbag should have a minimum of 50 feet of cord.

DRY BAG

An ultra-light and water-resistant dry bag is a good idea for storage and an extra level of protection and accessibility for gear.

HELMET

While calm, flatwater paddling in recreational, crossover, and touring boats generally does not require a helmet, we recommend wearing one for paddling anywhere near rocks or in heavy surf found in oceans and seas. In addition, a helmet should be used in rivers that are very shallow or that feature rapids above Class I and any other situation in which capsizing could result in your head hitting a jagged or hard surface.

FLOTATION BAGS

If you are forced to exit your kayak and it becomes swamped, recovery becomes more difficult. By installing inflatable float bags you can reduce the volume of water a swamped kayak will take on. Typical installation on a kayak will be two bags, one on either side of the stern pillar.

GET MORE ACCESSORIES

To find out about many more accessories available for your Dagger kayak, visit these websites:

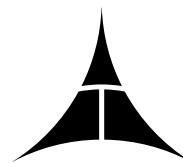

ADVENTURETECHNOLOGY

PADDLES

Premium paddles with innovative materials and patented technology unmatched on the water.

www.atpaddles.com



ACCESSORIES

A complete line of paddling accessories and outfitting at the best value in the industry.

www.harmonygear.com



ACCESSORIES

Premium sprayskirts and dry gear with material bonding techniques that set the standard in innovation.

www.bomborgear.com

LIMITED WARRANTY

TERMS AND CONDITIONS

For the original retail purchaser (“Consumer”), Dagger kayaks by Confluence Outdoor (**excluding whitewater kayak models**) are warranted against material or manufacturing defects in the hull and deck for **three (3) years** from date of original purchase of the kayak. Parts, accessories, and outfitting are warranted for a period of **one (1) year** against material or manufacturing defects from the date of purchase.

Dagger whitewater kayak models are warranted against material or manufacturing defects in the hull and deck for **three (3) years** from the date of purchase **based on the coverage levels detailed below.** Parts, accessories, and outfitting are warranted for a period of **one (1) year** against material or manufacturing defects from the date of purchase.

If you are unsure about what type of Dagger kayak you have purchased, consult the “Part ID” number as indicated on Manufacturer’s Statement of Origin (MSO). All Dagger whitewater kayak Part ID numbers begin with 901.

The following schedule details whitewater kayak coverage levels during the warranty term:

During the first year of ownership, this warranty covers repair or replacement of the hull, deck, outfitting, and all parts and accessories at 100% of the original retail price.

During the second year of ownership, this warranty covers repair or replacement of the hull and deck up to 80% of the original retail price.

During the third year of ownership, this warranty covers repair or replacement of the hull and deck up to 60% of the original retail price.

Dagger kayaks sold as “2nd quality” as indicated on the MSO are covered under this limited warranty for **one (1) year**

from the original purchase date for the hull, deck, outfitting, and all parts and accessories.

This limited warranty is only valid with the purchase of a Dagger kayak from a Dagger authorized dealer. This warranty is non-transferable.

HOW TO REGISTER YOUR BOAT

The warranty registration form should be completed online at www.dagger.com within 30 days of original purchase to be activated. It is suggested that you keep your sales receipt should it be required in the future for proof of purchase.

OBTAINING WARRANTY SERVICE

If you have a problem with your kayak and you suspect that it may be due to defective materials or workmanship, contact the nearest authorized Dagger dealer and arrange to have the problem inspected. Consumer is responsible for delivery to, and pickup from, the closest authorized dealer.

If the authorized Dagger dealer’s inspection indicates a defect that is attributable to materials or workmanship, Confluence Outdoor will repair or replace your Dagger kayak free of charge at the company’s option, based on the type of kayak and time of ownership corresponding to the warranty coverage schedule detailed above. Proof of purchase such as a sales receipt may be required. If repairs or evaluation are required by Dagger at its manufacturing facility, the Consumer will be responsible for a \$50.00 shipping and handling fee.

If service is required in a country that is not the country of purchase, Consumer will comply with all applicable export laws and regulations and be responsible for all customs duties, value add tax (VAT), and other associated taxes and charges. For international service,

the Dagger Distributor may repair or exchange defective products and parts with comparable products and parts that comply with local standards.

Confluence Outdoor retains the right to satisfy warranty via repair or replacement of products or of components deemed defective. In addition, Dagger reserves the right to replace original kayaks or equipment with comparable current products.

LIMITATIONS AND EXCLUSIONS

This limited warranty does not apply to:

- Normal wear and tear and aging of product.
- Kayaks damaged by extreme weather or environmental conditions.
- Kayaks damaged while in possession of a freight carrier, a dealer, Consumer, or any party other than Dagger.
- Kayaks damaged by accident, neglect, improper use or handling.
- Kayaks that have been towed by power or sail boats.
- Kayaks designated as Prototypes.
- Kayaks sold as “demos” or in “as is” condition.
- Kayaks determined to have been used for any activity other than an activity which is customary for the product.
- Kayaks that have been structurally or dimensionally altered or modified.
- Kayaks used for commercial or rental purposes.

This limited warranty excludes all other warranties, expressed or implied, including implied warranties of merchantability and fitness for a particular purpose, with regard to Dagger kayaks. Some state, country, or provincial laws do not allow the exclusion of certain implied warranties, so the above exclusion may not apply to you.

This limited warranty excludes any incidental or consequential damages or expenses resulting from any defects. Confluence Outdoor’s aggregate liability shall be limited to an amount equal to Consumer’s original purchase price paid for the defective product. Some state, country, or provincial laws do not allow the exclusion or limitation of incidental or consequential damages, so the above exclusion may not apply to you.

To the extent any limitation or exclusion contained herein is contrary to any country, state, or provincial law, such limitation or exclusion shall be severable and all other terms herein shall remain in full force and effect and are valid and enforceable.

This warranty gives you specific legal rights and you may also have other rights. For Consumers who are covered by state, country or provincial consumer protection laws or regulations, the benefits from this warranty are in addition to all rights conveyed by such consumer protection laws and regulations.

QUESTIONS?

Visit our Frequently Asked Questions section at www.dagger.com to answer these and many other commonly asked questions about our kayaks and accessories:

How do I adjust the seat?

How do I move the footbraces for solo paddling?

How do I use the skeg?

How can I get replacement parts?

What other accessories are available for my kayak?

FINDING YOUR SERIAL NUMBER

The serial number is located near the stern (rear) of the boat, just below the line where the deck and side meet. On most boats it is engraved in an indentation on the right side of the boat.

SERVICE & SUPPORT

IMPORTANT INFORMATION

Boat Model: _____

Serial Number: _____

Date of Purchase: _____

Dealer Name: _____

NOTICE: STATE REGULATIONS

Some states require that all kayaks be registered. To register your kayak you will need your Manufacturer’s Statement of Origin (MSO). This serves as the title to your kayak and should have been provided when you took delivery. If not, check with your retailer. If it has been lost, have your dealer contact Dagger and we will provide a replacement.

Note: Make sure the serial number on your MSO matches that on your hull.

SERVICE AND SUPPORT

If you have a problem with your kayak that you believe is covered under warranty, contact the nearest authorized dealer. You can find a listing of all dealers on our website.

If you have additional questions about your kayak or accessories, please visit our online support webpage at www.dagger.com for resources or to find information on contacting a customer service representative.

CONTACT US

(p) 888-52-KAYAK (888-525-2925)

(f) 888-373-1220

Service and support hours are Monday through Friday from 9 a.m. to 5:30 p.m. EST.

All warranties and part orders need to be handled through an authorized dealer, we do not sell direct.



59504182

© 2014 Confluence Outdoor

Confluence Outdoor
575 Mauldin Road, Suite 200
Greenville, SC 29607
www.dagger.com